

BOTTOM EQUIPMENT
SHAFT EXTENSION FOR
MIDLAND BOTTOM OUTLET VALVES

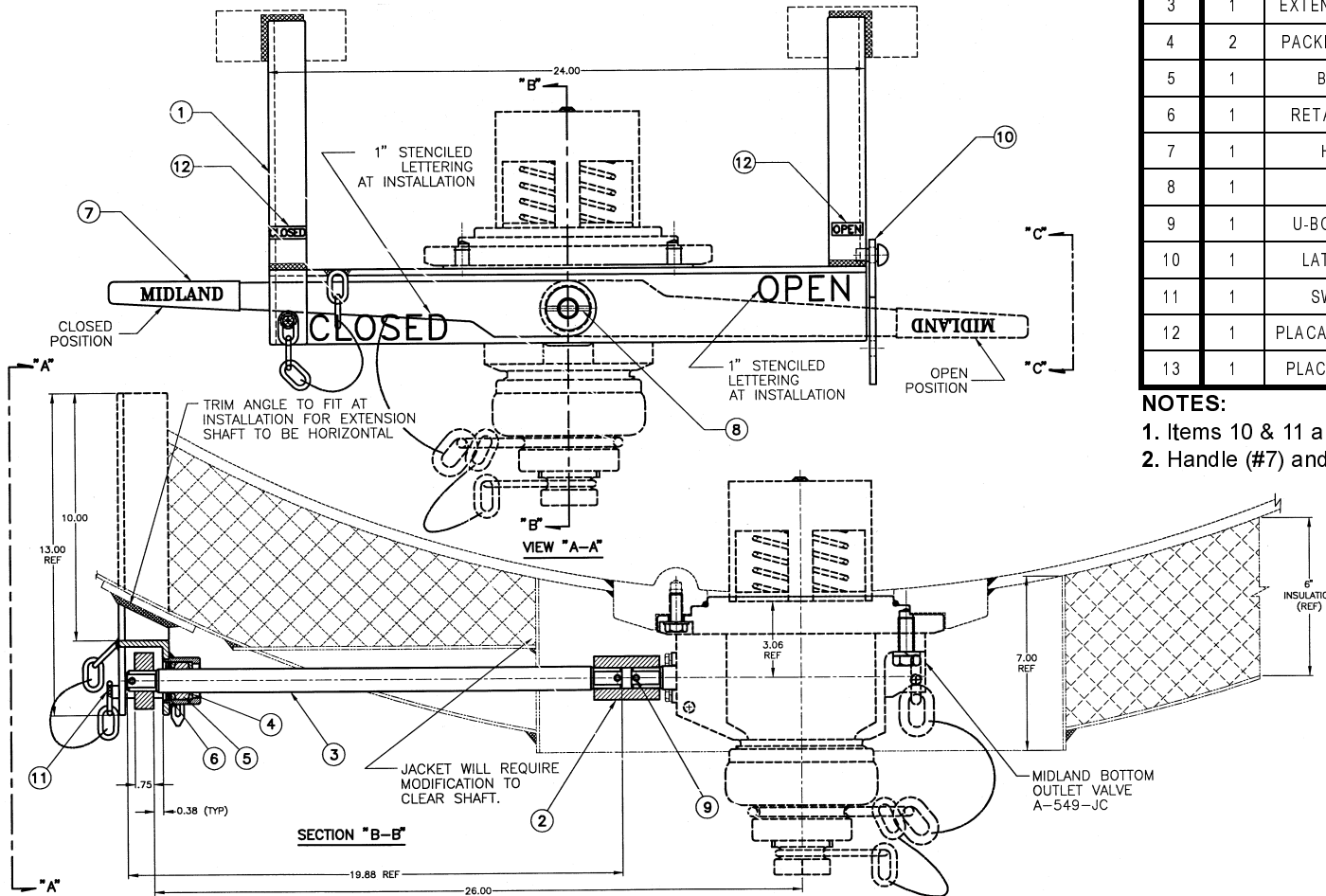

ITEM	QTY.	PART NAME	557-60-CS		NOTES
			MATERIAL	PART NO.	
1	1	BRACKET ASM.	STEEL	557-601-CS	
2	1	SHAFT COUPLING	STEEL	549-602-CS	
3	1	EXTENSION SHAFT	17-4PH-SS	549-603-SS	
4	2	PACKING WASHER	STEEL	545-9-CS	
5	1	BEARING	TEFLON	545-21-TF	
6	1	RETAINER RING	STAINLESS STEEL	549-604-SS	
7	1	HANDLE	STEEL	549-7-CS	2
8	1	PIN	STAINLESS STEEL	545-30-SS	2
9	1	U-BOLT & NUTS	STAINLESS STEEL	549-605-SS	
10	1	LATCH W/PIN	STEEL	557-610-CS	1
11	1	SWING PIN	STEEL	60-2-CS	1
12	1	PLACARD (CLOSED)	PLASTIC	71-1-PL	1
13	1	PLACARD (OPEN)	PLASTIC	72-1-PL	1

NOTES:

- Items 10 & 11 are part of welded bracket assembly (Item 1).
- Handle (#7) and pin (#8) are part of the valve assembly.

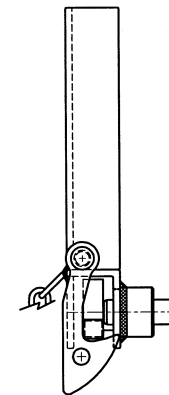

END VIEW "C-C"
 SHOWN WITH HANDLE
 IN OPEN POSITION



TO PLACE AN ORDER, OR JUST ASK A QUESTION, CALL (847) 677 - 0333 OR FAX (847) 677 - 0138

REVISION 4.0

12/28/98