

NOTES:

1 SIZE OF FLANGE

HOLES: Four 7/8" dia. holes are standard. For any other use suffix "J" and specify.

2 BOLT CIRCLE: 6-1/4" dia.

is standard. For 6-1/2" dia., use suffix "B". For any other, use suffix "C".

3 MOUNTING: The AAR standard tongue with an O.D. of 4.745"±.003" and an I.D. of 4.005"±.003" is standard. For a 4.995" x 4.255" tongue use suffix "M". For a 2.245" x 1.505" mounting use suffix "R". For flat face use suffix "P"

4 Alternate material available

ITEM NO.	QTY.	PART NAME	A-1700-SJ SERIES STAINLESS TRIM		A-1704-SJ SERIES STAINLESS STEEL	
			MATERIAL	PART NO.	MATERIAL	PART NO.
1	1	TOP GUIDE	STEEL	15-1-CS	STAINLESS	15-1-SS
2	1	STEM	STAINLESS	17-2-SS	STAINLESS	17-2-SS
3	1	PLUG	STAINLESS	17-3-SS	STAINLESS	17-3-SS
4	1	BODY	STEEL	15-442-CS	STAINLESS	15-442-MO
5	1	SPRING	STAINLESS	SEE TABLE	STAINLESS	SEE TABLE
6	1	FOLLOWER	STEEL	14-6-CS	STAINLESS	14-6-SS
7	1	GUIDE	STAINLESS	15-7-SS	STAINLESS	15-7-SS
8	1	TOP NUT	STEEL	15-8-CS	STEEL ⁽⁴⁾	15-8-CS
9	1	TOP GASKET	BUNA-N ⁽⁴⁾	15-9-BN	BUNA-N ⁽⁴⁾	15-9-BN
10	1	SHAFT SEAL	TEFLON	17-10-TF	TEFLON	17-10-TF
11	1	ADJUSTMENT SCREW	STAINLESS	15-11-SS	STAINLESS	15-11-SS
12	1	SEAL RETAINER	STEEL	17-12-CS	STAINLESS	17-12-SS
13						
14	1	CAP	STAINLESS	15-14-SS	STAINLESS	15-14-SS
15	1	SET SCREW	STEEL	15-15-CS	STEEL	15-15-CS
16	3	BOLT	STEEL	15-16-CS	STAINLESS	15-16-SS
17	3	LOCKWASHER	STEEL	15-17-CS	STAINLESS	15-17-SS
18	1	WIRE SEAL	LEAD/SS	15-18-PB	SS/LEAD	15-18-PB
19	1	RETAINER	STAINLESS	17-19-SS	STAINLESS	17-19-SS
20	1	SEAT 'O' RING	BUNA-N ⁽⁴⁾	10-10-BN	BUNA-N ⁽⁴⁾	10-10-BN
21	1	PLUG 'O' RING	BUNA-N ⁽⁴⁾	10-11-BN	BUNA-N ⁽⁴⁾	10-11-BN
22	1	NAMEPLATE	STAINLESS	SEE TABLE	STAINLESS	SEE TABLE

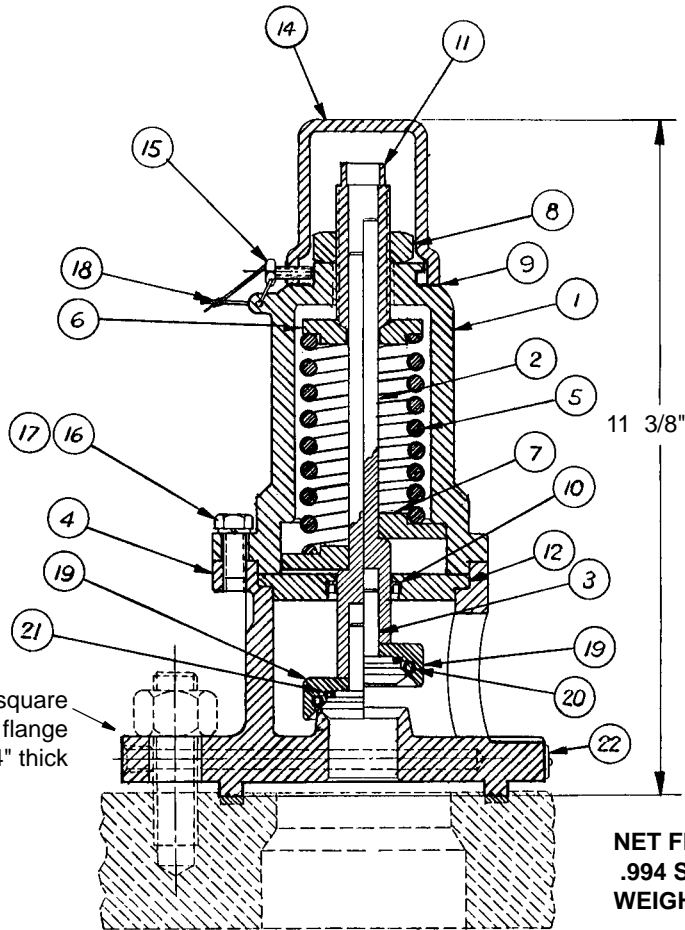

NET FLOW AREA:
.994 SQUARE INCHES
WEIGHT OF VALVE: 22 LBS.

PRESSURE SETTING (PSIG)	FLOW RATE (SCFM-AIR)	SPRING P/N	A-1700-SJ SERIES STAINLESS TRIM		A-1704-SJ SERIES STAINLESS STEEL	
			VALVE P/N	NAMEPLATE	VALVE P/N	NAMEPLATE
75	1340	15-75-MO	A-1775-SJ	17-24-SS	A-1779-SJ	17-28-SS
150	1960	15-150-SS	A-17150-SJ	17-25-SS	A-17154-SJ	17-29-SS
165	2827	15-165-SS	A-17165-SJ	17-44-SS	A-17169-SJ	17-48-SS
225	3250	15-225-SS	A-17225-SJ	17-26-SS	A-17229-SJ	17-30-SS
247.5	3368	15-300-SS	A-17247-SJ	17-45-SS	A-17251-SJ	17-49-SS
255	3490	15-300-SS	A-17255-SJ	17-53-SS	A-17259-SJ	17-54-SS
280.5	3782	15-300-SS	A-17280-SJ	17-46-SS	A-17284-SJ	17-51-SS
300	4020	15-300-SS	A-17300-SJ	17-34-SS	A-17304-SJ	17-35-SS
330	3935	15-375-SS	A-17330-SJ	17-47-SS	A-17334-SJ	17-52-SS
375	3646	15-375-SS	A-17375-SJ	17-36-SS	A-17379-SJ	17-37-SS
450	4198	15-450-SS	A-17450-SJ	17-40-SS	A-17454-SJ	17-41-SS

PRESSURE RELIEF VALVES

A-1700-SJ SERIES and A-1704-SJ SERIES

TOP STYLE

PRESSURE RELIEF VALVES