

**PRESSURE RELIEF VALVES**

**A-17150-T thru A-17454-T**

**TOP STYLE**

© 2002 Midland Manufacturing Corp.

All designs subject to change without notice. Installation dimensions and mounting arrangements are for general information. Certified drawings are available upon request.

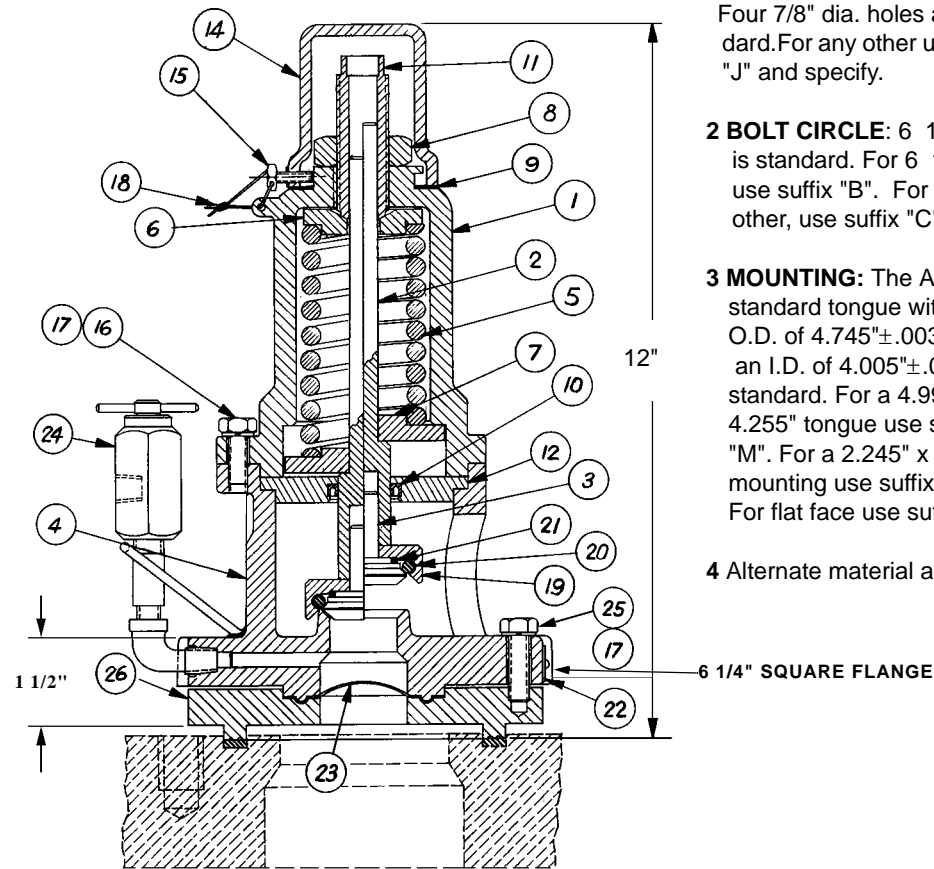

**NOTES:**

**1 SIZE OF FLANGE HOLES:**  
Four 7/8" dia. holes are standard. For any other use suffix "J" and specify.

**2 BOLT CIRCLE:** 6 1/4" dia. is standard. For 6 1/2" dia. use suffix "B". For any other, use suffix "C".

**3 MOUNTING:** The AAR standard tongue with an O.D. of 4.745"±.003" and an I.D. of 4.005"±.003" is standard. For a 4.995" x 4.255" tongue use suffix "M". For a 2.245" x 1.505" mounting use suffix "R". For flat face use suffix "P".

**4 Alternate material available**

**NET FLOW AREA: .994 SQUARE INCHES**  
**WEIGHT OF VALVE: 25 LBS.**

ITEM NO.	QTY.	PART NAME	A-17150-T THRU A-17450-T STAINLESS TRIM		A-17154-T THRU A-17454-T STAINLESS STEEL	
			MATERIAL	PART NO.	MATERIAL	PART NO.
1	1	TOP GUIDE	STEEL	15-1-CS	STAINLESS	15-1-SS
2	1	STEM	STAINLESS	17-2-SS	STAINLESS	17-2-SS
3	1	PLUG	STAINLESS	17-3-SS	STAINLESS	17-3-SS
4	1	BODY	STEEL	15-44-CS	STAINLESS	15-44-MO
5	1	SPRING	STAINLESS	SEE TABLE	STAINLESS	SEE TABLE
6	1	FOLLOWER	STEEL	14-6-CS	STAINLESS	14-6-SS
7	1	GUIDE	STAINLESS	15-7-SS	STAINLESS	15-7-SS
8	1	TOP NUT	STEEL	15-8-CS	STEEL <sup>(4)</sup>	15-8-CS
9	1	TOP GASKET	BUNA-N <sup>(4)</sup>	15-9-BN	BUNA-N <sup>(4)</sup>	15-9-BN
10	1	SHAFT SEAL	TEFLON	17-10-TF	TEFLON	17-10-TF
11	1	ADJUSTMENT SCREW	STAINLESS	15-11-SS	STAINLESS	15-11-SS
12	1	SEAL RETAINER	STEEL	17-12-CS	STAINLESS	17-12-SS
13						
14	1	CAP	STAINLESS	15-14-SS	STAINLESS	15-14-SS
15	1	CAP SCREW	STEEL	15-15-CS	STEEL	15-15-CS
16	3	BOLT	STEEL	15-16-CS	STAINLESS	15-16-SS
17	5	LOCKWASHER	STEEL	15-17-CS	STAINLESS	15-17-SS
18	1	WIRE SEAL	SS/LEAD	15-18-PB	SS/LEAD	15-18-PB
19	1	RETAINER	STAINLESS	17-19-SS	STAINLESS	17-19-SS
20	1	SEAT "O" RING	BUNA-N <sup>(4)</sup>	10-10-BN	BUNA-N <sup>(4)</sup>	10-10-BN
21	1	PLUG "O" RING	BUNA-N <sup>(4)</sup>	10-11-BN	BUNA-N <sup>(4)</sup>	10-11-BN
22	1	NAMEPLATE	STAINLESS	SEE TABLE	STAINLESS	SEE TABLE
23	1	RUPTURE DISC	STAINLESS <sup>(4)</sup>	AS SPECIFIED	STAINLESS <sup>(4)</sup>	AS SPECIFIED
24	1	NEEDLE VALVE NIPPLE & ELBOW	STAINLESS	A-253-BN <sup>(4)</sup> 421-SS	STAINLESS	A-253-BN <sup>(4)</sup> 421-SS
25	2	BOLTS	STEEL	17-31-SS	STAINLESS	17-31-SS
26	1	RUPTURE DISC FLANGE	STEEL	17-34-CS	STAINLESS	17-34-SS

PRESSURE SETTING (PSIG)	FLOW RATE (SCFM-AIR)	SPRING P/N	A-17150-T thru A-17450-T STAINLESS TRIM		A-17154-T thru A-17454-T STAINLESS STEEL	
			VALVE P/N	NAMEPLATE P/N	VALVE P/N	NAMEPLATE P/N
150	1960	15-150-SS	A-17150-T	17-25-SS	A-17154-T	17-29-SS
165	2827	15-165-SS	A-17165-T	17-44-SS	A-17169-T	17-48-SS
225	3250	15-225-SS	A-17225-T	17-26-SS	A-17229-T	17-30-SS
247.5	3368	15-300-SS	A-17247-T	17-45-SS	A-17251-T	17-49-SS
255	3490	15-300-SS	A-17255-T	17-53-SS	A-17259-T	17-54-SS
280.5	3782	15-300-SS	A-17280-T	17-46-SS	A-17284-T	17-51-SS
300	4020	15-300-SS	A-17300-T	17-34-SS	A-17304-T	17-35-SS
330	3935	15-375-SS	A-17330-T	17-47-SS	A-17334-T	17-52-SS
375	3646	15-375-SS	A-17375-T	17-375-SS	A-17379-T	17-37-SS
450	4198	15-450-SS	A-17450-T	17-40-SS	A-17454-T	17-41-SS



TO PLACE AN ORDER, OR JUST ASK A QUESTION, CALL (847) 677 - 0333 OR FAX (847) 677 - 0138

REVISION 4.0

6/23/05