

PRESSURE RELIEF VALVES

A-1735-T and A-1739-T

TOP STYLE

© 2002 Midland Manufacturing Corp.

All designs subject to change without notice. Installation dimensions and mounting arrangements are for general information. Certified drawings are available upon request.

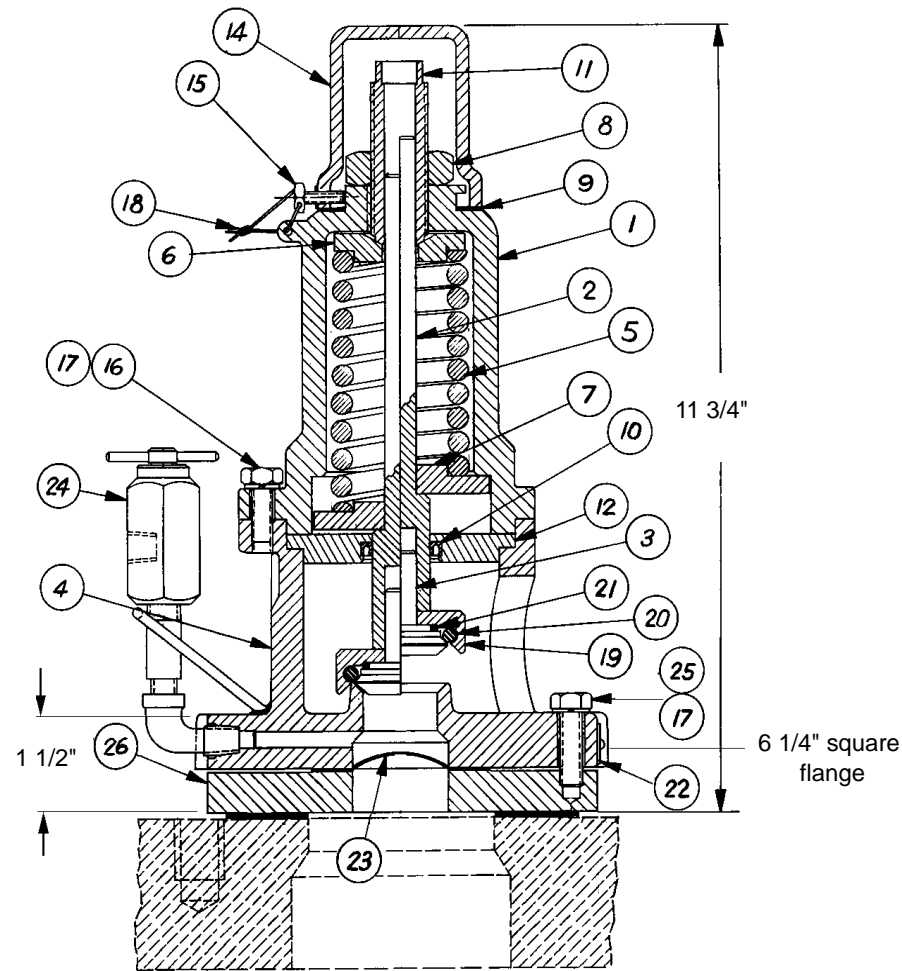

NET FLOW AREA: .994 SQUARE INCHES
WEIGHT OF VALVE: 25 LBS.

PRESSURE SETTING (PSIG)	FLOW RATE (SCFM-AIR)
35	730

ITEM NO.	QTY.	PART NAME	A-1735-T STAINLESS TRIM		A-1739-T STAINLESS STEEL	
			MATERIAL	PART NO.	MATERIAL	PART NO.
1	1	TOP GUIDE	STEEL	15-1-CS	STAINLESS	15-1-SS
2	1	STEM	STAINLESS	17-2-SS	STAINLESS	17-2-SS
3	1	PLUG	STAINLESS	17-3-SS	STAINLESS	17-3-SS
4	1	BODY	STEEL	15-42-CS	STAINLESS	15-42-MO
5	1	SPRING	STAINLESS	15-35-MO	STAINLESS	15-35-MO
6	1	FOLLOWER	STEEL	14-6-CS	STAINLESS	14-6-SS
7	1	GUIDE	STAINLESS	15-7-SS	STAINLESS	15-7-SS
8	1	TOP NUT	STEEL	15-8-CS	STEEL ⁽⁴⁾	15-8-CS
9	1	TOP GASKET	BUNA-N ⁽⁴⁾	15-9-BN	BUNA-N ⁽⁴⁾	15-9-BN
10	1	SHAFT SEAL	TEFLON	17-10-TF	TEFLON	17-10-TF
11	1	ADJUSTMENT SCREW	STAINLESS	15-11-SS	STAINLESS	15-11-SS
12	1	SEAL RETAINER	STEEL	17-12-CS	STAINLESS	17-12-SS
13						
14	1	CAP	STAINLESS	15-14-SS	STAINLESS	15-14-SS
15	1	SET SCREW	STEEL	15-15-CS	STEEL	15-15-CS
16	3	BOLT	STEEL	15-16-CS	STAINLESS	15-16-SS
17	5	LOCKWASHER	STEEL	15-17-CS	STAINLESS	15-17-SS
18	1	WIRE SEAL	SS/LEAD	15-18-PB	SS/LEAD	15-18-PB
19	1	RETAINER	STAINLESS	17-19-SS	STAINLESS	17-19-SS
20	1	SEAT *O* RING	BUNA-N ⁽⁴⁾	10-10-BN	BUNA-N ⁽⁴⁾	10-10-BN
21	1	PLUG *O* RING	BUNA-N ⁽⁴⁾	10-11-BN	BUNA-N ⁽⁴⁾	10-11-BN
22	1	NAMEPLATE	STAINLESS	17-21-SS	STAINLESS	17-23-SS
23	1	RUPTURE DISC	STAINLESS ⁽⁴⁾	AS SPECIFIED	STAINLESS ⁽⁴⁾	AS SPECIFIED
24	1	NEEDLE VALVE NIPPLE & ELBOW	STAINLESS	A-253-BN ⁽⁴⁾ 421-SS	STAINLESS	A-253-BN ⁽⁴⁾ 421-SS
25	2	BOLTS	STEEL	17-31-SS	STAINLESS	17-31-SS
26	1	RUPTURE DISC FLANGE	STEEL	17-32-CS	STAINLESS	17-32-SS

NOTES:

- 1 SIZE OF FLANGE HOLES:** Four 3/4" dia. holes are standard. For any other use suffix "J" and specify.
- 2 BOLT CIRCLE:** 5 1/2" dia. is standard. For 6 1/2" dia. use suffix "B". For any other, use suffix "C".
- 3 MOUNTING:** Flat face flange is standard. For a 4.995" x 4.255" tongue use suffix "M". For a 2.245" x 1.505" mounting use suffix "R".
- 4 Alternate material available**



TO PLACE AN ORDER, OR JUST ASK A QUESTION, CALL (847) 677 - 0333 OR FAX (847) 677 - 0138

REVISION 4.0

4/21/05