

VACUUM RELIEF VALVES  
1 1/2", NPT WITH SCREEN

© 2002 Midland Manufacturing Corp.  
All designs subject to change without notice. Installation dimensions and mounting arrangements are for general information. Certified drawings are available upon request.

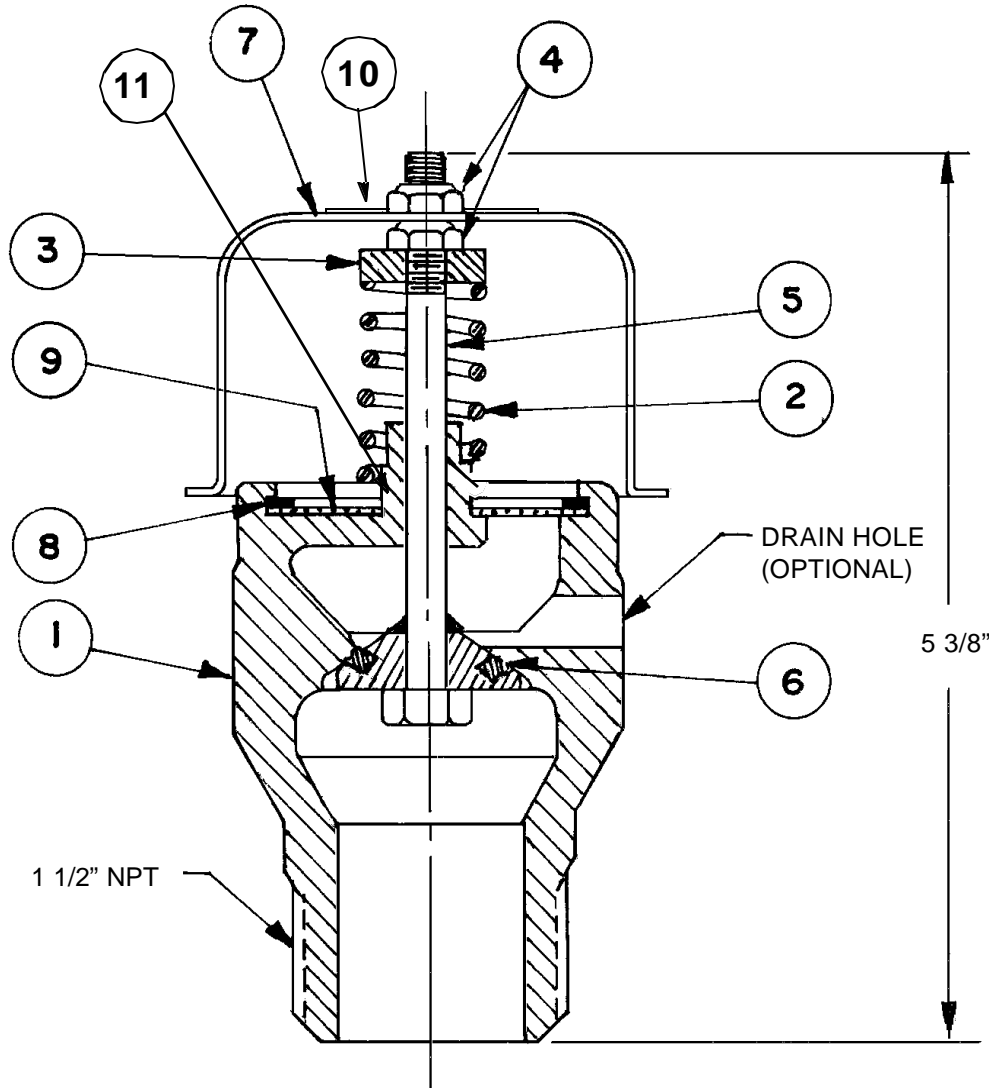

ITEM NO.	QTY.	PART NAME	A-217-WS	
			MATERIAL	PART NO.
1	1	BODY	STAINLESS	217-101-MO
2	1	SPRING	STAINLESS	SEE TABLE
3	1	SPRING SEAT	STAINLESS	217-3-SS
4	2	LOCK NUT	STAINLESS	217-4-SS
5	1	STEM	STAINLESS	217-5-SS
6	1	PRESSURE SEAL	BUNA-N <sup>(1)</sup>	215-6-BN
7	1	WEATHER CAP	STAINLESS	215-7-SS
8	1	RETAINING RING	STAINLESS	217-8-SS
9	1	SCREEN ASSEMBLY	STAINLESS	217-9-SS
10	1	NAMEPLATE	STAINLESS	215-86-SS
11	1	SPACER	STAINLESS	222-10SS

NOTE: 1 Alternate material available

Standard minimum start to discharge pressure setting is 0.75 PSI vacuum.  
Alternate vacuum settings are shown in table.

VACUUM SETTING (PSI)	SPRING P/N
.75	215-2-MO
3	215-27-MO
4	215-23-MO
5-8	215-24-MO
10	215-25-MO

Net flow area: 0.71 square inches

