

© 2002 Midland Manufacturing Corp.

All designs subject to change without notice. Installation dimensions and mounting arrangements are for general information. Certified drawings are available upon request.

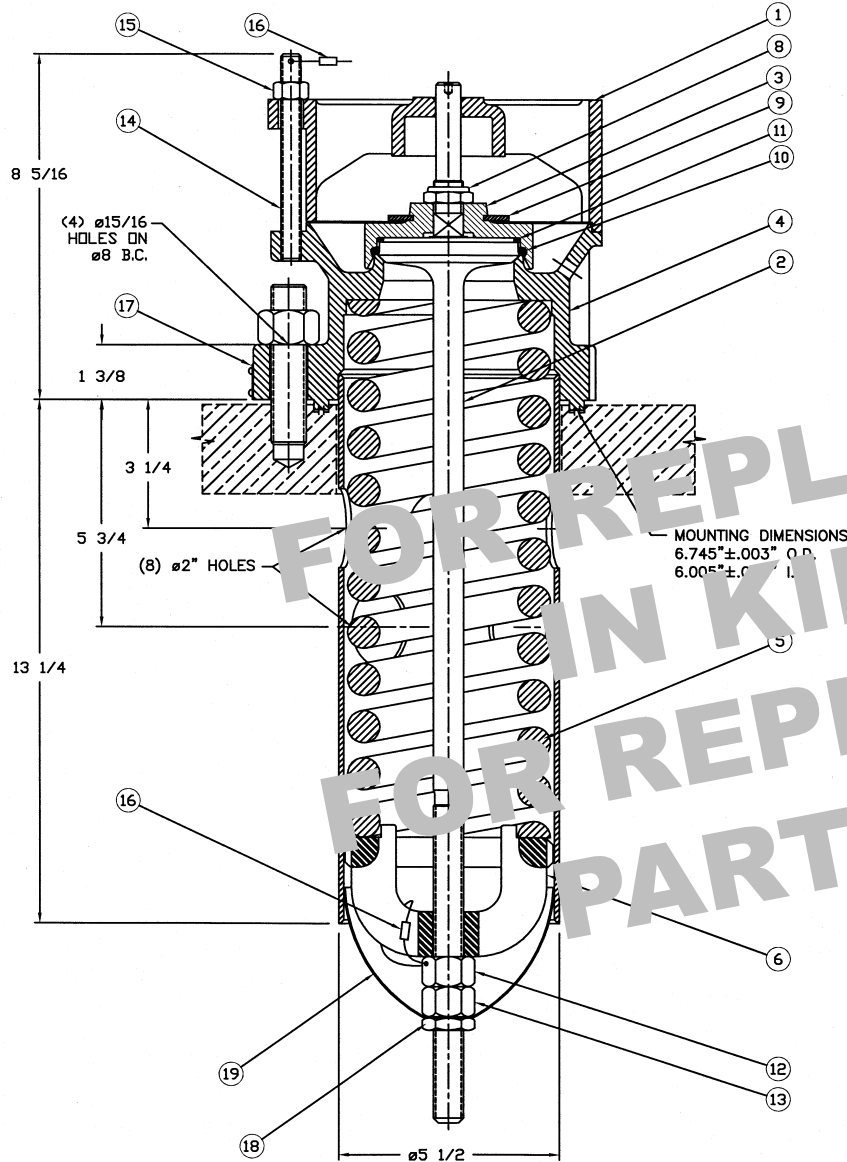

ITEM NO.	QTY.	PART NAME	MATERIAL	PART NO.
1	1	TOP GUIDE	STEEL W/SS INSERT	34-1-XS
2	1	STEM	STAINLESS	31-2-SS
3	1	RETAINER	STEEL, PLATED ⁽¹⁾	31-3-CS ⁽⁴⁾
4	1	BODY & GUIDE ASM	STEEL	34-411-CS
5	1	SPRING	ALLOY STEEL, PLATED ⁽³⁾	SEE TABLE
6	1	FOLLOWER	STEEL, PLATED	34-6-CS
7				
8	1	TOP LOCK NUT	STEEL, PLATED ⁽¹⁾	23-8-CS
9	1	WASHER	NEOPRENE	23-9-NE
10	1	SEAT "O" RING	BUNA-N ⁽²⁾	31-10-BN
11	1	STEM "O" RING	BUNA-N ⁽²⁾	31-11-BN
12	1	ADJUSTMENT NUT	STEEL, PLATED ⁽¹⁾	23-12-CS
13	1	LOCK NUT	STEEL, PLATED ⁽¹⁾	23-13-CS
14	4	STUD	ALLOY STEEL	31-14-AS
15	4	NUT	STEEL	23-15-CS
16	2	WIRE SEAL	SS/LEAD	23-7-PB
17	1	NAMEPLATE	STAINLESS	SEE TABLE
18	1	COVER LOCK NUT	STEEL, PLATED	310-5-CS
19	1	COVER	STAINLESS	34-66-SS

NOTES: 1 Standard plating is zinc or cadmium. 2 Alternate materials available. 3 Standard plating is zinc with dichromate. For aluminum coated spring, specify AS/AL. For stainless steel spring, specify SS. 4 Replacement retainer is 37-3-CS. Order new nameplate per A-37000-XL valve table for correct pressure.

PRESSURE SETTING (PSIG)	FLOW RATE (SCFM-AIR)	NAMEPLATE PART NO.	VALVE PART NO.	SPRING PART NO. ⁽³⁾
150	20,500	34-18-SS	A-3450-XL	34-150-AS
225		34-26-SS	A-34225-XL	34-225-AS
247		34-23-SS	A-34247-XL	34-255-AS
255		34-19-SS	A-3455-XL	34-255-AS
280.5		34-17-SS	A-3480-XL	34-5-AS
300		34-20-SS	A-3400-XL	34-5-AS
330		34-25-SS	A-3430-XL	34-5-AS

THESE VALVES ARE REPLACED BY VALVES IN THE A-37000-XL SERIES



TO PLACE AN ORDER, OR JUST ASK A QUESTION, CALL (847) 677 - 0333 OR FAX (847) 677 - 0138

REVISION 4.0

8/11/02