

© 2002 Midland Manufacturing Corp.

All designs subject to change without notice. Installation dimensions and mounting arrangements are for general information. Certified drawings are available upon request.

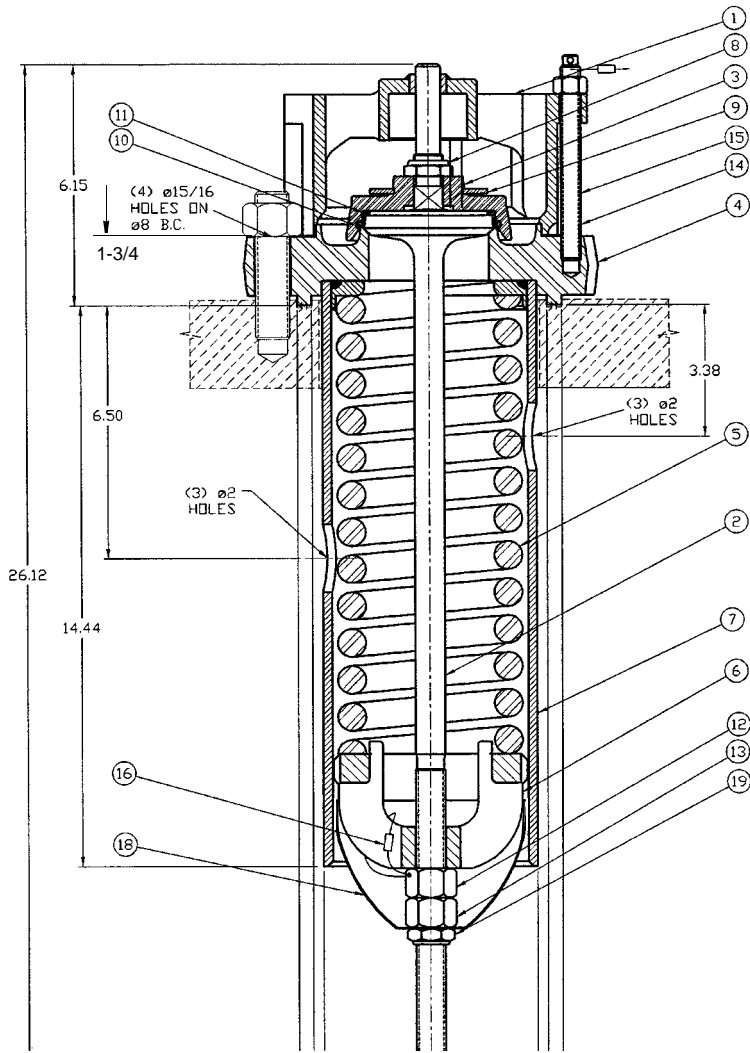

ITEM NO.	QTY.	PART NAME	A-35000-XL SERIES		A-35004-XL SERIES	
			MATERIAL	PART NO.	MATERIAL	PART NO.
1	1	TOP GUIDE	STEEL W/SS INSERT	35-101-XS	STAINLESS	35-101-SS
2	1	STEM	STAINLESS	32-2-SS	STAINLESS	32-2-SS
3	1	RETAINER	STEEL, PLATED ⁽¹⁾	35-3-CS	STAINLESS	35-3-SS
4	1	BODY	STEEL	35-41-CS	STAINLESS	35-41-SS
5	1	SPRING	ALLOY STEEL, PLATED ⁽³⁾	SEE TABLE	STAINLESS	SEE TABLE
6	1	FOLLOWER	STEEL, PLATED ⁽¹⁾	32-6-CS	STAINLESS	32-6-SS
7	1	SPRING GUIDE ASSEMBLY	STEEL	32-7-CS	STAINLESS	32-7-SS
8	1	TOP LOCK NUT	STEEL, PLATED ⁽¹⁾	23-8-CS	STAINLESS	23-8-SS
9	1	WASHER	NEOPRENE	23-9-NE	NEOPRENE	23-9-NE
10	1	SEAT *O*-RING	BUNA-N ⁽²⁾	32-10-BN	BUNA-N ⁽²⁾	32-10-BN
11	1	STEM *O*-RING	BUNA-N ⁽²⁾	32-11-BN	BUNA-N ⁽²⁾	32-11-BN
12	1	ADJUSTMENT NUT	STEEL, PLATED ⁽¹⁾	23-12-CS	STAINLESS	23-12-SS
13	1	LOCK NUT	STEEL, PLATED ⁽¹⁾	23-13-CS	STAINLESS	23-13-SS
14A	2	STUD	ALLOY STEEL	31-14-AS	STAINLESS	31-14-SS
14B	2	STUD W/ HOLE	ALLOY STEEL	31-141-AS	ALLOY STEEL	31-141-AS
15	4	NUT	STEEL	10-15-CS	STAINLESS	10-15-SS
16	2	WIRE SEAL	SS/LEAD	10-16-PB	SS/LEAD	10-16-PB
17	1	NAMEPLATE	STAINLESS	SEE TABLE	STAINLESS	SEE TABLE
18	1	COVER	STAINLESS	32-66-SS	STAINLESS	32-66-SS
19	1	COVER LOCK NUT	STEEL, PLATED ⁽¹⁾	310-5-CS	STAINLESS	310-5-SS

NOTES: 1 Standard plating is zinc or cadmium. 2 Alternate materials available. 3 Standard plating is zinc w/dichromate. For aluminum coated spring, specify AS/AL. For stainless steel spring, specify SS. 4 Consult factory.

PRES-SURE SETTING (PSIG)	FLOW RATE (SCFM-AIR)	NAMEPLATE PART NO.	A-35000-XL SERIES		A-35004-XL SERIES	
			VALVE PART NO.	SPRING PART NO. ^(#3)	VALVE PART NO.	SPRING PART NO.
225	(4)		A-35225-XL	(4)	A-35229-XL	(4)
247.5	(4)		A-35247-XL	(4)	A-35251-XL	(4)
255	(4)		A-35255-XL	(4)	A-35259-XL	(4)
280.5	33,122	35-281-SS	A-35280-XL	35-280-AS	A-35284-XL	(4)
300	(4)		A-35300-XL	(4)	A-35304-XL	(4)
330	(4)		A-35330-XL	(4)	A-35334-XL	(4)

THESE VALVES REPLACE A-3200-XL SERIES VALVES

NET FLOW AREA: 6.91 SQUARE INCHES
WEIGHT OF VALVE: 74 LBS.



TO PLACE AN ORDER, OR JUST ASK A QUESTION, CALL (847) 677 - 0333 OR FAX (847) 677 - 0138

REVISION 4.0

1/26/05