

LONGITUDINAL SECTION "B-B"

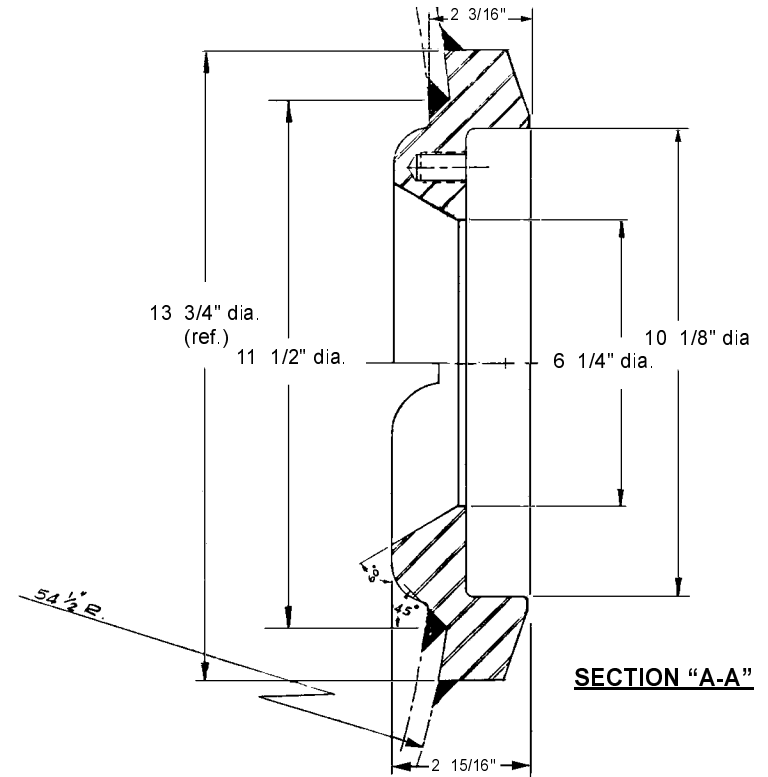

PART NUMBER	MATERIAL
B-363-SSL	ASTM A182 GR F304L
B-363-MOL	ASTM A182 GR F316L