

© 2002 Midland Manufacturing Corp.

All designs subject to change without notice. Installation dimensions and mounting arrangements are for general information. Certified drawings are available upon request.

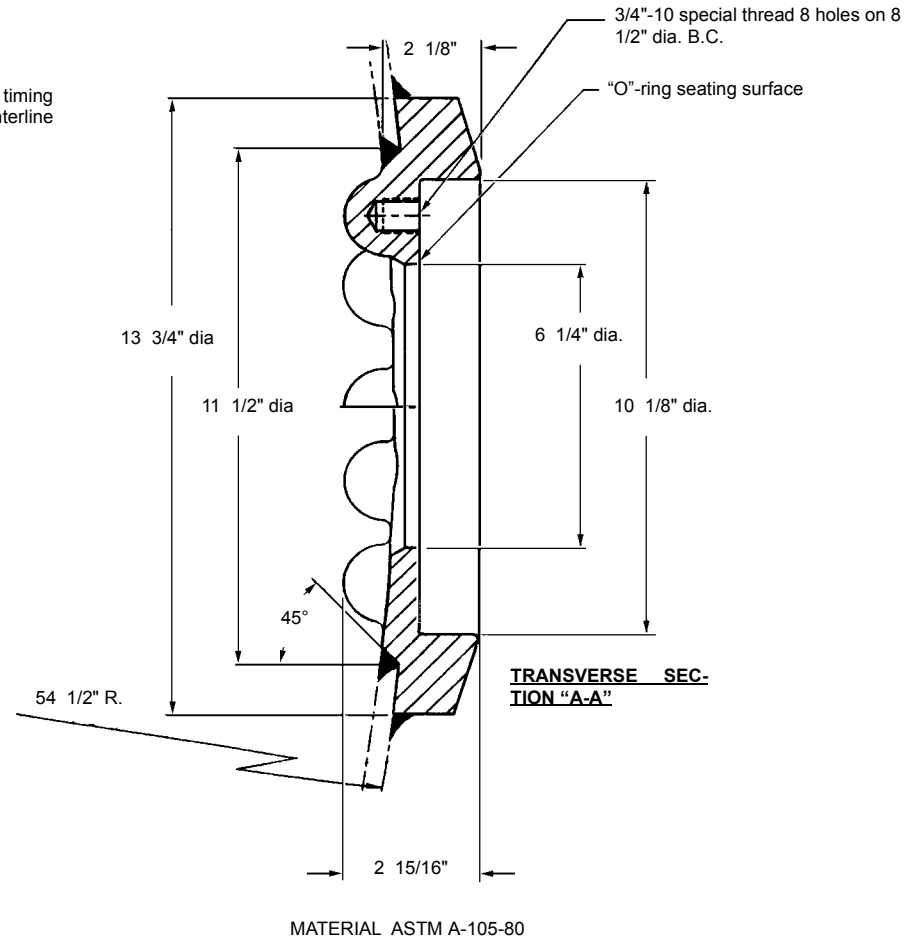

LINE	PART NUMBER	MINIMUM TENSILE STRENGTH (PSI)
00	B-363-CS	70,000

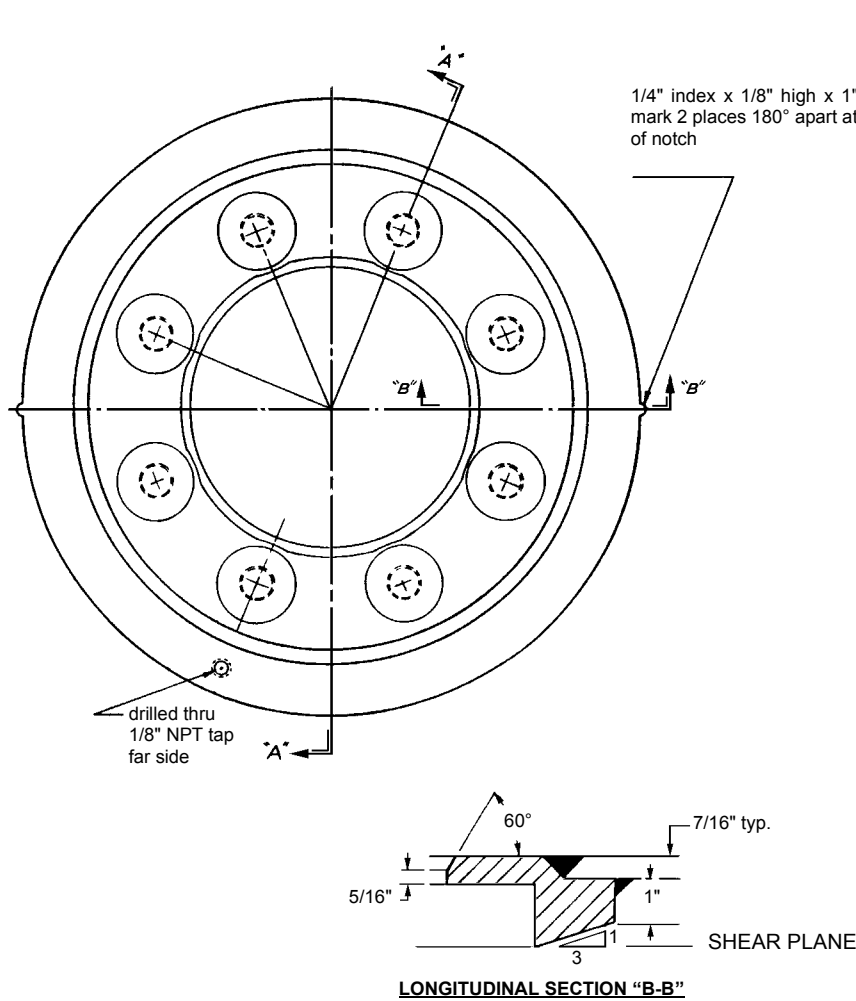