

GAGING DEVICES

LIQUID LEVEL GAGE

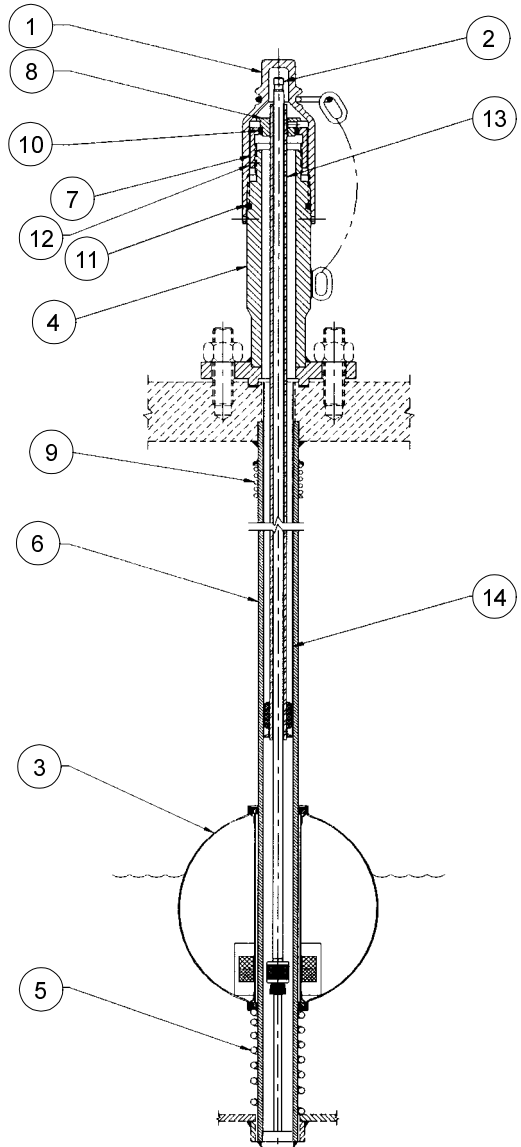

ITEM NO.	QTY.	PART NAME	MATERIAL	PART NO.
1	1	COVER W/CHAIN	DUCTILE IRON/STEEL ⁽⁴⁾	612-1-DI
2	1	LOWER GAGE ROD ASSEMBLY ⁽¹⁾	FIBERGLASS	612-2-FG
3	1	FLOAT ASSEMBLY ⁽²⁾	STAINLESS ⁽⁴⁾	612-3-SS
4	1	BODY ASSEMBLY ⁽⁵⁾	STEEL ⁽⁴⁾	612-4-CS
5	1	BOTTOM SPRING	STAINLESS ⁽⁴⁾	612-5-SS
6	1	GUIDE TUBE ASSEMBLY ⁽³⁾	STAINLESS ⁽⁴⁾	612-6-SS
7	1	INSTALLATION CORRECTION NUT	STEEL, PLATED ⁽⁴⁾	612-7-CS
8	1	SPECIFIC GRAVITY ADJUSTMENT BUSHING ⁽¹⁾	PLASTIC	612-8-PS
9	1	TOP SPRING	STAINLESS ⁽⁴⁾	612-55-SS
10	1	"O" RING	SILICONE	612-10-SI
11	1	"O" RING	BUNA-N ⁽⁴⁾	612-11-BN
12	1	SET SCREW	STEEL ⁽⁴⁾	612-12-CS
13	1	UPPER GAGE ROD ASSEMBLY	FIBERGLASS	612-13-FG
14	1	UPPER GAGE ROD SUPPORT TUBE	STAINLESS	612-14-SS

- NOTES: 1 Length, scale, and calibration per application.
 2 Float diameter of 5", 6" or 7 1/2" selected per application.
 3 Length per application.
 4 Alternate materials available.
 5 Various mountings available.

Patent number 5,020,637



