

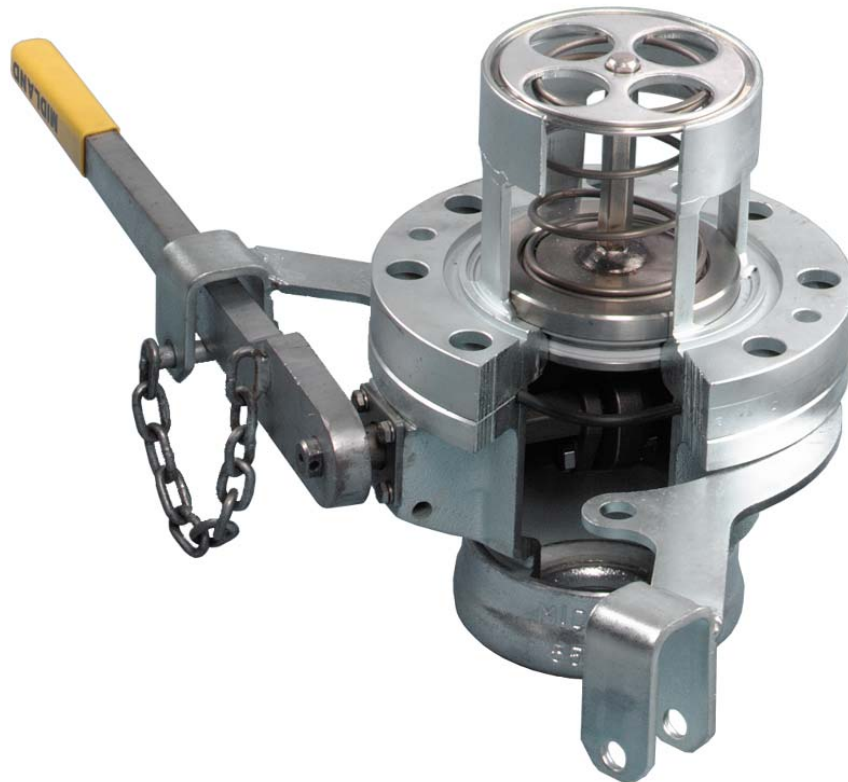

Bottom Outlet Plug Valves

Installation
Operation
Inspection
Maintenance

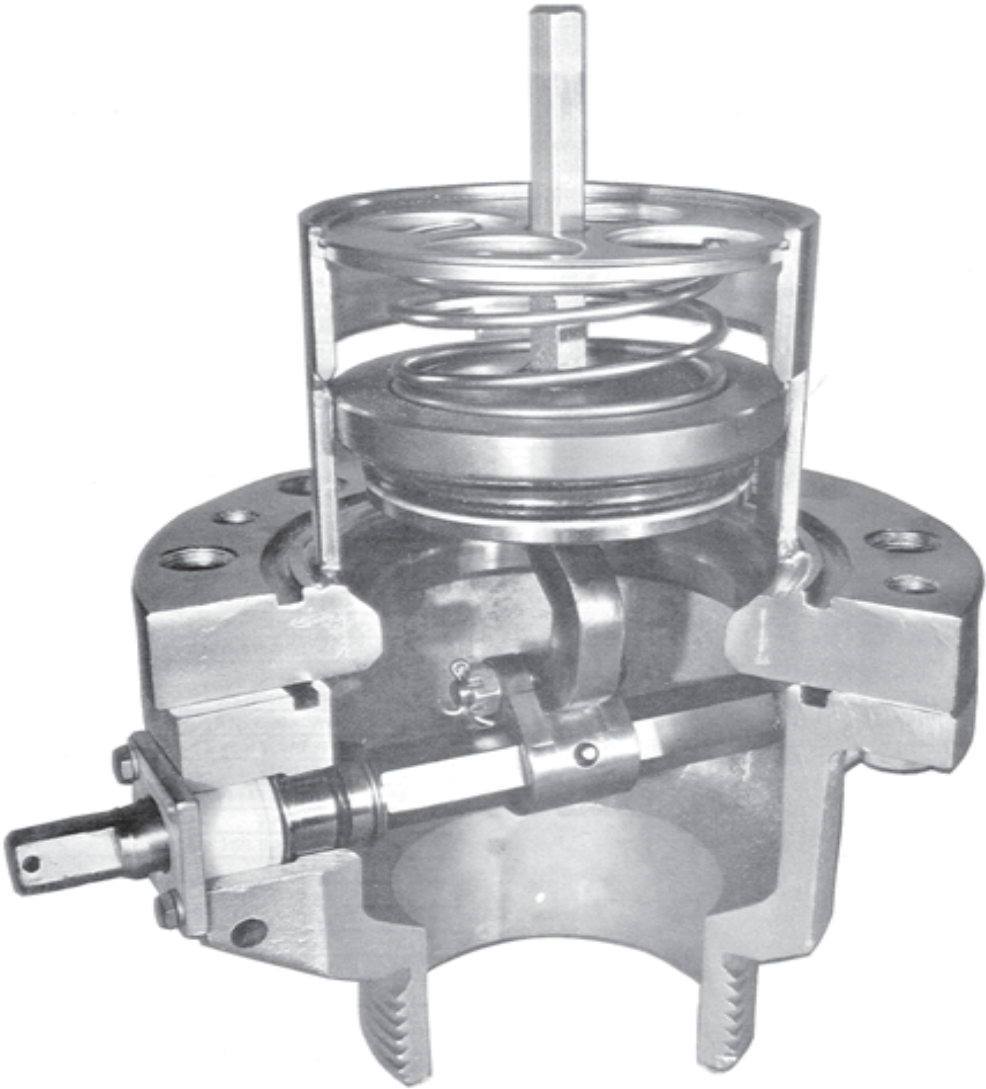



**CAUTION-IMPORTANT SAFEGUARDS**

Midland valves are used in connection with a variety of products, many of which are hazardous materials and could cause serious injury or damage.

Always use extreme caution and proper equipment when involved with hazardous materials.

This valve should only be used by qualified personnel.

Read all of these instructions carefully before proceeding.

SAVE THESE INSTRUCTIONS!

ITEM NO.	PART NAME
1	TOP GUIDE
2	SHAFT
3	GASKET RETAINER
4	BODY
5	SPRING
6	RETAINER COVER
7	HANDLE
8	PACKING FLANGE
9	PACKING WASHER
10	SEAT "O" RING
11	BORE "O" RING
12	SHAFT "O" RING
13	BUSHING "O" RING
14	WIPER RING
15	CAM LEVER
16	CAM
17	CAM BOLT
18	RETAINER RING
19	SHAFT BUSHING
20	PACKING BUSHING
21	PACKING
22	PACKING SPRING
23	GUIDE STEM
24	RETAINER RING
25	PACKING BOLT
26	RETAINER BOLT
27	CAM STEM NUT
28	CAM STEM PIN
29	CAM PIN
30	HANDLE PIN
31	BASE
32	BASE BOLT, LKW
33	BASE "O" RING
34	BODY "O" RING
35	PIN
36	CAP ASM.
37	EYEBOLT, NUT, LKW.
38	BODY BOLT, LKW.
OPTIONAL PARTS	
50	STEAM JACKET ASSEMBLY
51	HEAT TRANSFER CEMENT
52	BOLT, NUT, LOCKWASHERS
53	INSULATION JACKET
54	INSULATION
55	SPIRAL RING
56	NUT, WASHER, LKW.

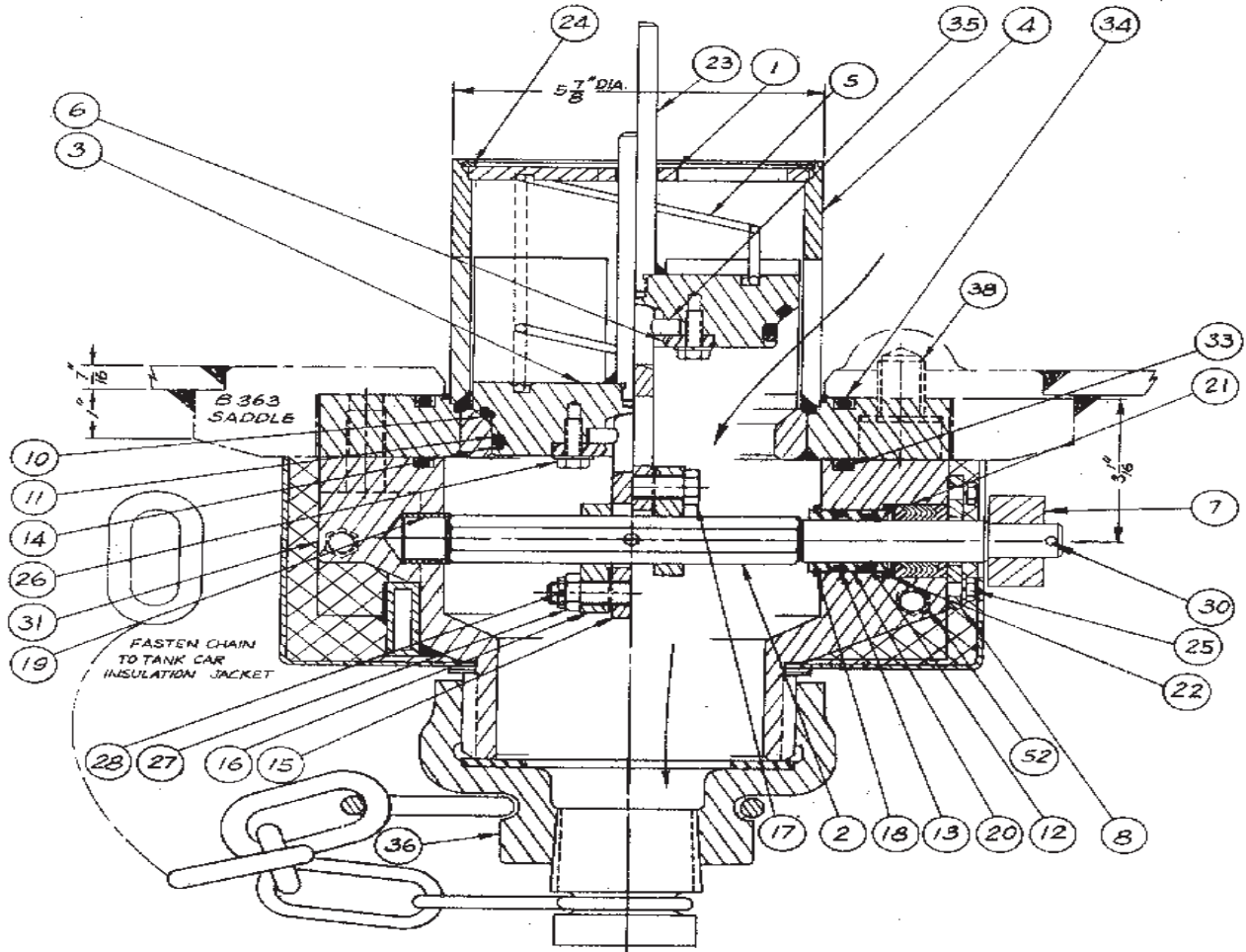

NOTE :
 ROTATE SHAFT AT LEAST 150° CCW. TO OPEN VALVE.
 SECURE HANDLE IN OPEN POSITION WHILE UNLOADING.

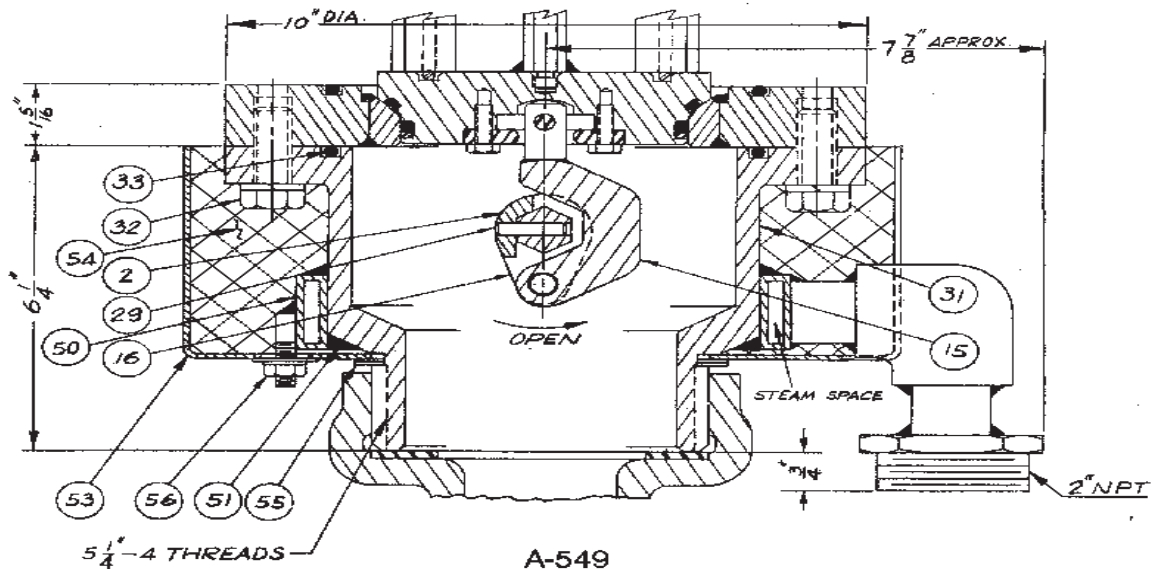

A-549

Installation Instructions



CAUTION: Be sure the car is empty and clean, and the work area is free of hazardous chemicals that may have been in the car, before removing a valve or installing a new one.

The Midland Bottom Outlet Valve may be mounted on the tank car universal flange, or on a Midland tank saddle, such as B-363, or on saddles furnished by other companies. These mountings have different bolt circles, so the mounting flanges on the valves are different.

A. It may be possible to install the valves without completely separating the valve into two parts. When installing the valve on a universal flange, or if there is no insulation in the valve area, some crews have installed our valve by using the following steps:

1. Thoroughly clean off the inside of the universal flange or mounting saddle. Be sure there are no nicks, burrs, grit, paint, coatings, or any other residue on this surface, or on the top flanged surface of the valve's upper section. Saddle surfaces should be flat within .015 inches TIR after welding.
2. The valve should be in the closed position, resting on a clean surface.
3. If the valve has an insulation jacket around a steam coil, it will be necessary to remove the insulation jacket, but **not** the steam coil. To remove the jacket, spread the retaining ring, positioned just above the 5¼" thread, and start the end of the retaining ring into the thread. Then rotate the ring, unscrewing it completely off the 5¼" threaded end. Take off the two 5/16" nuts and washers from the threaded studs. As the cover is lifted off, the two window covers will slide off. Unwrap the insulation. Bear in mind that after installing the valve on the car, all of these accessories should be repositioned in the reverse order they were taken off.
4. Remove the shear bolts (item number 32).
5. Rotate the valve handle (item number 7) to the open position (180° counter clockwise) as you spread the upper and lower sections apart.
6. Verify that the cotter pin (item number 28) has been spread with both legs folded back around the nut.
7. Take out the eight 3/4-10 socket head screws and lock washers.
8. The entire valve, with the outlet cap in place weighs 75 to 95 pounds, depending upon the type. Therefore, it is necessary to have mechanical assistance or additional manpower available to position the valve.
9. Orient the upper flange, so that the 5/8" shear bolt holes straddle the longitudinal and transverse axes of the car.
10. The Midland saddles contain a special lock thread, but the universal flanges and saddles made by other companies frequently do not. For these flanges, it would be desirable to use a thread sealant, such as Loctite, on the end of the threads of the 3/4-10 screws. Install the socket head capscrews with lock washers. For the O-ring sealed flanges designed for metal to metal contact, torque the 3/4-10 socket head cap screws to 225 ft.lbs.
11. Using a straight-edge, check the exposed surface of the socket head cap screws to be sure they are screwed completely up inside the recessed counterbore in the flange. Later when the lower half is bolted in place, the two flanges must mate without being held apart

Installation Instructions (cont.)

by the head of the cap screw.

12. Rotate the handle clockwise to the closed position, raising the lower half of the valve to the upper half, and aligning the shear bolt holes.
13. Install the four 5/8" shear bolts and lock washers. The upper flange is tapped with a special lock thread, so it is not necessary to use a thread sealant, such as Loctite. These two flanges are bolted together metal to metal. Torque the 5/8" shear bolts to 90 ft.lbs.
14. Be sure to test the valve for leakage in accordance with **Section C in Installation Instructions**.

B. If you install the valve by disconnecting the upper and lower sections, use the following procedure:

1. Thoroughly clean off the inside of the universal flange or mounting saddle. Be sure there are no nicks, burrs, grit, paint, coatings, or any other residue on this surface, or on the top flanged surface of the valve's upper section. Saddle surfaces should be flat within .015 inches TIR after welding.
2. The valve should be in the closed position, resting on a clean surface.
3. Remove the four 5/8" shear bolts (item number 32).
4. Rotate the valve handle (item number 7) to the open position (180° counter clockwise).
5. Spread the upper and lower sections of the valve apart, so that you can reach into the lower section from the side, or reach into the inside of the valve from the discharge end of the valve.
6. Remove the cotter pin (item number 28) and the cam stem nut (item number 27).
7. Remove the cam bolt (item number 17).
8. Separate the upper and lower parts of the valve.
9. The upper section of the valve weighs about 32 to 52 pounds, depending upon the type, so it may be desirable to have mechanical assistance or additional manpower to help position the upper part to its mounting. Orient the upper flange, so that the 5/8" shear bolt holes straddle the longitudinal and transverse axes of the car.
10. The Midland saddles contain a special lock thread, but the universal flanges and saddles made by other companies frequently do not. For these flanges, it would be desirable to use a thread sealant, such as Loctite, on the end of the threads of the cap screws. Install the socket head capscrews with lockwashers. For the O-ring sealed flanges designed for metal to metal contact, torque the 3/4" socket head cap screws to 225 ft.lbs.
11. Using a straight-edge, check the exposed surface of the socket head cap screws to be sure they are screwed completely up inside the recessed counterbore in the flange. Later when the lower half is bolted in place, the two flanges must mate without being held apart by the head of the cap screw.
12. Inspect the upper flange surface of the lower valve section and the lower flange surface of the top valve section to be sure the mating surfaces, particularly where the O-ring is to seal, are free of dirt, nicks, burrs and

Installation Instructions (cont.)

scratches. The lower half of the valve, including the valve cap, but not a steam coil, weighs 53 pounds, so it may be desirable to have mechanical assistance or additional manpower to help attach the upper and lower halves together

13. Reconnect the cam (item number 16) with the cam lever (item number 15) by reinserting the cam bolt (item number 17). It may be necessary to reorient the cam lever by rotating it about its vertical axis. Put a screwdriver in the 1/2" hole in the cam lever, or use a small adjustable wrench to turn the cam lever. The cam lever must be oriented properly, with the open section between the two halves of the cam facing in the same direction as the recess in the cam lever. This will then permit the cam lever to completely close without hitting the cam when the valve is closed. If you can't rotate the shaft to draw the upper and lower

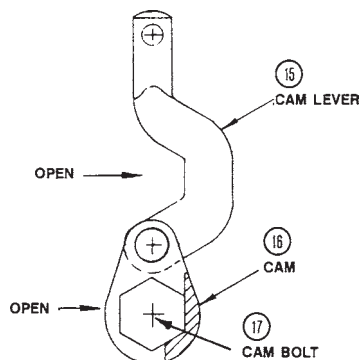

halves of the valve together with the valve closed, the cam lever (item number 15) has probably been oriented 180° out of position. If this is the case, reorient the cam lever.

14. Screw on the cam stem nut (item number 27) hand-tight until the slots of the nut are aligned with the cotter pin hole. The cam bolt is a pivot, so it does not need to be wrenched tightly, just "snugged up."

15. Insert the cotter pin, and spread both legs out and back around the nut. If it is hard to keep the nut and cam bolt in place to insert the cotter pin, after properly positioning these parts, put tension on them to keep them from moving by closing the valve.
16. Rotate the valve handle approximately 180° to draw up the lower half of the valve. It is important that the valve handle is oriented so that when the upper half is bolted to the lower half, the handle will fit into the bracket that locks it in the closed position.
17. Install the four 5/8" shear bolts and lock washers. The upper flange is tapped with a special lock thread, so it is not necessary to use a thread sealant, such as Loctite. Torque the 5/8" bolts to 90 ft.lbs.

18. The stenciling on the car shows the open and

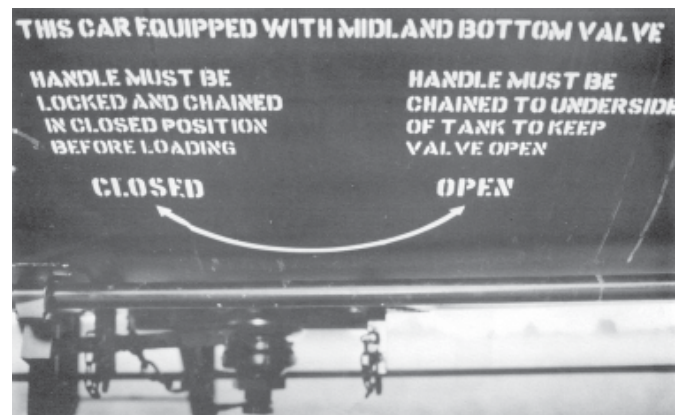

closed positions of the valve handle. Pin the handle in the closed position, removing the valve cap, and check that the cam is in the low position to assure that the valve is closed. Open and close the valve a few times to be sure it moves freely, and check that the valve handle fits into both the open and closed brackets that secure the handle.

C. Test the valve after Installation, as follows:

1. With the valve closed and the bottom cap in

Installation Instructions (cont.)

place, pressurize the car to check for leaks.

- a. between the universal flange or saddle and the upper flange of the valve
 - b. Then slightly back off the cap or the 2" pipe plug to see if any air was trapped. If air escapes, this would indicate there was a leak in the orifice area of the valve.
2. Tighten the bottom cap or pipe plug and open the valve. Inspect for leaks between: a. the valve flange connection between the upper and lower halves of the valve. b. the valve and the valve cap and plug. c. the packing gland on the side of the valve handle.
 3. It may be necessary to loosen the valve cap slightly to relieve trapped liquid to fully close the valve, since the valve cannot be closed when the bottom outlet leg is full of an incompressible liquid.

Operating Instructions

D. To open the valve:

1. Conform with all applicable TC, AAR, and DOT regulations (Parts 173.31, 174.67, Pamphlet 34, etc.).



CAUTION: When loading or unloading, the vacuum relief valve's proper operation must be verified, and the vent valve or manway cover opened to avoid either compressing air in loading the tank, or drawing a vacuum when unloading.

2. Be sure the valve handle is in the closed

position, as shown by the car's stenciling. As an added precaution, loosen the 2" pipe plug in the valve cap and look for any accumulation of product or indication that the valve is leaking or was improperly installed, so that the valve is actually open.

3. If there are no adverse indications, proceed to hook up the loading or unloading lines, unscrewing the 4" outlet cap (if the 4" connection is used) or the 2" pipe plug.
4. Rotate the valve handle from the closed to the open position. Approximately 25 pounds force at the handle end is needed to open this valve against a 25 psi tank pressure.



CAUTION: Do not use an extension or cheater on the valve handle. If it does not move freely, report this to the tank car supervisor. The tank may be pressurized, contain solidified product, or the valve may be jammed.

5. For unloading, the valve handle must be secured in the open position. If it is not properly pinned open in the bracket, the handle will automatically swing toward the closed position.

E. To close the valve:

1. Remove the pin from the bracket that keeps the handle in the open position. Rotate the handle up to the bracket on the closed side. The handle must then be secured in the closed position with a pin and swivel that has a slot for a car seal, or by a lock, to prevent its unauthorized opening later.



CAUTION: Do not use an extension or cheater on the valve handle. If it doesn't move freely, report this to the supervisor.

Maintenance

2. Disconnect the product line and wash out the lower valve chamber with a compatible cleaning material. Clean off the threads and the flat face surface of the valve. Also clean off the threads and gasket inside the outlet cap.
3. Install and then tighten up the outlet cap using a wrench with a 36" minimum-length handle (as required in DOT 173.3(b)).

F. Routine Maintenance



CAUTION: Under no circumstances

should the valve be operated unless the tank car is empty and the valve is free of product.

1. Verify that the four 5/8" shear bolts (item number 32) have not loosened up. The split lock washers must be flat.
2. Inspect for evidence of leakage along the external flange surfaces, and in the shaft packing gland area.
3. Check the threads and gasket of the outlet cap to verify that they are in good condition.
4. Inspect the threads and the flat surface of the valve that seals against the outlet cap gasket. They should be free of solidified product, nicks or other impediments to achieve a tight seal.

G. Leakage Through the Valve. The most likely cause for leakage through the valve is due to deteriorated O-rings. The procedure for replacing O-rings in the gasket retainer (item number 3) is as follows:

1. Be sure there is no product or pressure in the car.
2. Open the valve by rotating the handle to the bracket on the open side and pin it in this position.
3. Carefully loosen the outlet cap or pipe plug to verify that there is no pressure or product present.
4. Close the valve by rotating the handle into the closed bracket and pin it in place.
5. Remove the outlet cap.
6. With needlenose pliers, reach in through the discharge port and take out the cotter pin (item number 28). If the cotter pin is not easy to reach, the cam bolt can be rotated when the load is taken off it by partially opening the valve. If you still cannot take out the cotter pin, go to step 9 for better access. Remove the cotter pin and then follow with steps 7 and 8.
7. After removing the cotter pin, unscrew the slotted nut (item number 27).
8. Pull the cam bolt (item number 17) that holds the cam and cam lever together. If you want to take off the valve handle for ease in handling the valve, note the orientation of the valve handle. Mark the top or bottom, since the handle is not symmetrical or reversible. Remove the handle pin and the handle.
9. Remove the four 5/8" shear bolts (item number 32). Take off the lower half of the valve, and put it on a clean surface.
10. To take the O-rings out of the gasket retainer, you can take the upper half of the valve off the car. Or you may find it easier to remove the

Maintenance (cont.)

gasket retainer from inside the car, assuming the car is safe to enter, without demounting the valve. If you decide on the latter, skip step 11.

11. To remove the upper half of the valve, unscrew the eight 3/4" socket head cap screws. The upper half of the valve can now be taken off the car and placed on a clean surface.
12. Start to remove the retainer ring (item number 24) by using a small screwdriver to peel it, beginning at the cutaway section of the ring. Since there is a compressed spring (item number 5) below the top guide (item number 1), push down firmly on the top guide with sufficient force to keep it in position as the retainer ring is peeled out of its groove.



CAUTION: Do not permit the top guide to fly up. About 50 pounds of force is necessary to restrain the spring.

13. Pull out the gasket retainer. Inspect the outside surface of the O-rings for any cracks, embrittlement, abnormal swelling or surface discontinuities.
14. If the O-rings need replacement, carefully take them out of the grooves with the rounded end of a 6" scale, a small screwdriver, or other blunt ended tool.



CAUTION: Do not scratch the O-ring groove, as a scratch could cause a leak path around the O-ring.

15. O-rings 10 and 11 are not interchangeable. The upper O-ring (item number 10) is much

harder (90 durometer) and less elastic than the lower one. Use only the proper O-ring for each groove. Clean out the grooves. Lubricate the replacement O-rings with an appropriate grease to ease installation. Be sure the O-rings are replaced without twisting.

16. While the gasket retainer is out of the valve, try rotating the cam lever. It should be free to move. If it is not, flush out the cavity. If it still sticks, take the four hex head bolts (item number 26) out and see if the pin (item number 35) is bent. The pin should be straight, and the retainer cover (item number 6) should be free of burrs or scores.
17. Also look carefully at the 45° tapered valve seat and the cylindrical surface of the valve orifice or bore. The O-rings seal on both surfaces, so any nicks, scratches, product deposits, or other imperfections will permit pressure to pass around the O-ring seal. Running your fingernail over these surfaces should be adequate to sense any imperfections.
18. Reassemble the valve following the above steps in reverse. Install the valve following the installation instructions, including testing.

H. Shaft Packing Gland Leakage.



NOTE: It is necessary to remove the lower half of the valve to repack the packing gland. Follow the procedure in paragraphs G.1 through G.9 of the "Leakage Through the Valve" section.

1. Note the orientation of the valve handle. Mark the top or bottom side, since the handle is not symmetrical or reversible.

Maintenance (cont.)

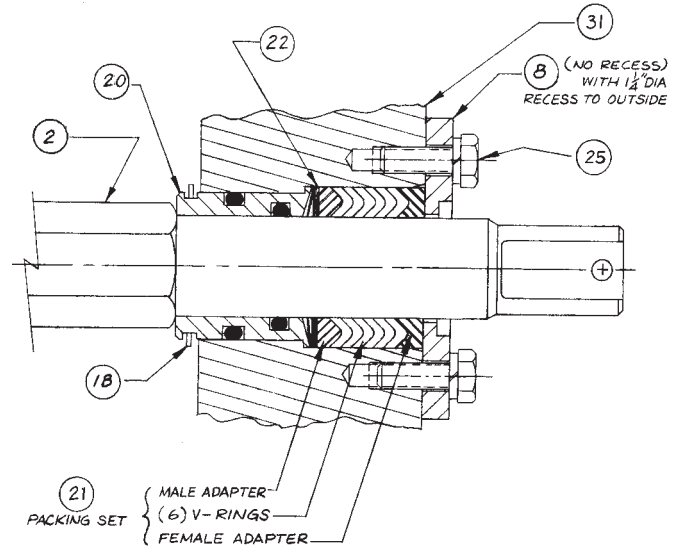
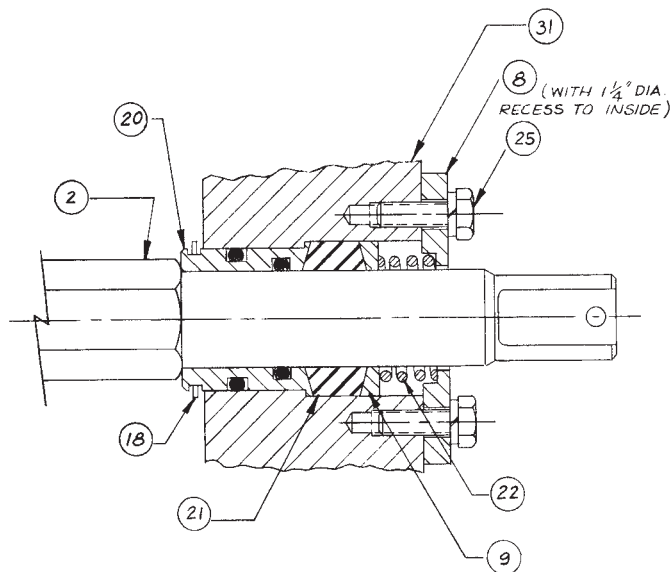

2. Tap out the handle pin (item number 30) and remove the handle.

3. Unscrew the packing gland bolts.



CAUTION: Many older valves, a

compressed coil spring (item number 25) is beneath the square packing flange (item number 9). Newer valves have a wave spring and chevron V-ring packing in place of a coil spring and a one-piece tubular shaped teflon packing.

4. Remove the square packing flange and the coil spring, if present.

5. Remove the retainer ring (item number 18) from the packing bushing (item number 20) groove and leave it on the hex surface of the shaft (item number 2).

6. Use the shaft to press the packing bushing, teflon packing, and washer out of the valve base (item number 31).

7. If changing the packing from the old style one-piece teflon to the chevron V-rings, it will be necessary to put a chamfer, or tapered lead-in, about 1/8" long by 15 degrees, into the side hole in the base (item number 31). This can be done with a burr knife or a small rat-tail file. This is necessary so that the outside edges of the chevron V-rings do not get scraped by the sharp edge of the hole.

8. When renewing the O-rings and/or the teflon packing, use an ample amount of grease to facilitate the reassembly.

9. Replace the parts in the reverse order. Then follow paragraphs B.12 through B.18 of the Installation Instructions.

10. After the reconnection of the lower section of the valve with the upper section, test it in accordance with paragraphs C.1 through C.3.

NOTICES AND WARRANTY

REGULATIONS

Midland Bottom Outlet Plug Valves are used in contact with a variety of products, many of which are hazardous materials. The acceptance and transportation of products are regulated by the DOT and AAR in the U.S.A., and in Canada by CTC and Transport Canada. Regulations of other governmental bodies must be complied with for stationary and mobile applications. All personnel should be familiar with and follow these regulations. Nothing in these instructions is intended to conflict with or supersede these regulations.

The information in this document was gathered from knowledgeable sources, but Midland Manufacturing Corporation makes no representations or guarantees about its accuracy or completeness and assumes no liability for this information. Specifications are subject to change without notice.

Obtaining Product Drawings

Assembly drawings of Midland Bottom Outlet Plug Valves are available at no charge, and will be mailed upon request. Address any questions concerning valve maintenance or usage to the Engineering Dept., Midland Manufacturing Corp.

Warranty

Midland warrants the products of its own manufacture to be free of defects in material and workmanship for a period of one (1) year from the date of invoice. Furnished materials and accessories purchased from other manufacturers are warranted only by and to the extent of those manufacturers' warranties, if any.

MIDLAND MAKES NO WARRANTY OF ANY KIND WHATSOEVER, EXPRESS OR IMPLIED, OTHER THAN AS SPECIFICALLY STATED HERE. MIDLAND MAKES NO WARRANTIES OF MERCHANTABILITY OR FITNESS FOR ANY

PARTICULAR PURPOSE OR USE. Midland's obligation under this warranty is strictly limited, at its option, to 1) repair or replacement at its factory of a like quantity of product: 2) refunding to purchaser money paid to Midland for its product: or 3) issuance of written authorization for the Purchaser to repair or replace, at costs comparable to Midland's normal manufacturing costs those parts proven defective, provided that Purchaser has given to Midland immediate notice upon discovery of such defect. Merchandise claimed to be defective shall not be returned without first obtaining Midland's written consent. The undertaking of repair or replacement by the Purchaser, or its agents, without Midland's written consent, shall void Midland's warranty and relieve Midland of all responsibility. Under no circumstances shall Midland be liable for any direct, incidental, consequential or other damages of any kind in connection with the installation, operation, maintenance, repair, inspection or other use of any product purchased from it.



A **DOVER** RESOURCES COMPANY

Mail to: P.O. Box 226, Skokie, IL 60076-0226
7733 Gross Point Road, Skokie, IL 60076-0226
Phone: (847)677-0333, Fax: (847)677-0138