



Excess Flow Check Valves

Installation
and
Operation



CAUTION: IMPORTANT SAFEGUARDS

Midland valves are used in connection with a variety of products, many of which are hazardous materials and could cause serious injury or damage.

Always use extreme caution and proper equipment when involved with hazardous materials. This valve should only be handled by qualified personnel.

Read all of these instructions carefully before proceeding.

SAVE THESE INSTRUCTIONS!

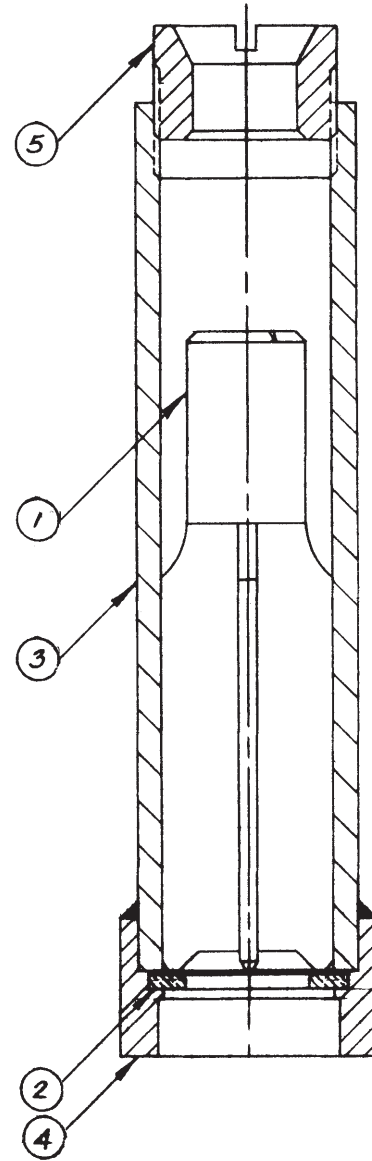

ITEM NO.	PART NAME
1	FLOAT
2	WASHER
3	BODY
4	COUPLING
5	PLUG

Function

It should be fully understood by all users of the restricted usefulness and purpose of excess flow check valves (abbreviated as EFCV). They can be relied upon to close only when the outward flow through the valve exceeds a predetermined amount of product.



WARNING: Valve Misuse

EFCV valves are not to be used to protect against product loss during loading or unloading in the event of a line rupture.

Valves designed for line rupture protection are available. These valves provide manual, remote, and thermally activated shut off capability. All operating personnel should be alerted to this limitation of EFCV. In railroad tank car operation, EFCV serve only to protect the tank in the event that exterior valves are removed.

Operation

1. As stated in the preceding paragraph, the EFCV has a flow rated capacity (subject to a variation or tolerance due to many factors). Most EFCV are equipped with a bypass, so that product will still flow through the valve when it has checked. The bypass is designed into the valve to permit pressure to equalize above and below the float when the valve downstream is closed off, thus enabling the float of the EFCV to unseat. Therefore it is *never* safe to remove a valve directly above an EFCV, unless some flow of discharging product can be safely handled.
2. In a derailment accident, where tank cars are rolled over, the gravity actuated float in the EFVC will probably close below the rated capacity of the EFCV because the flow rate capacity is established when the valve is vertical and flow is upward.

Installation



NOTE: Conform to all regulations and your company's installation instructions. It is not the intention of this pamphlet to conflict with or supersede these requirements.

1. If the valve has been disassembled during the installation procedure, it is critical that the float be put back into the valve body in the correct orientation. For our 2" and 3" EFCV, the top of the float is flat across, with a small (about 1/8" x 45°) chamfer on the O.D. to mate with the valve's seat.
2. Be sure the float will slide freely up and down in the valve body. If the float had been taken out of the valve, inspect it to see that there are no burrs, nicks or gouges on the exterior guiding surfaces that could restrict the free movement of the float.
3. When welding the valve into its mounting, be careful not to get weld splatter on the inside of the valve body. Also, do not permit the valve body to become distorted when welding it in place.
4. If the valve has a removable seat, the valve seat should be tightened down so that it does not become disengaged in transit. Torque the seat down securely. Midland has a wrench available to tighten down the seat.

NOTICES AND WARRANTY

Midland Excess Flow Check Valves are used in a variety of products, many of which are hazardous materials. The acceptance and transportation of the products are regulated by the DOT and AAR in the U.S.A., and in Canada by the CTC and Transport Canada, as well as other governmental bodies, particularly when used in stationary applications. All personnel should be familiar with and follow these regulations. Nothing in this pamphlet is intended to conflict with or supersede these regulations.

Obtaining Product Drawings

Assembly drawings of Midland Excess Flow Check Valves are available at no charge, and will be mailed upon request. Address any questions concerning valve maintenance or usage to the Engineering Dept., Midland Manufacturing Corp.

The information contained herein is thought to be reliable. It was gathered from knowledgeable sources, but Midland Manufacturing Corp. makes no representations or guarantees about its accuracy or completeness and assumes no liability for this information.

Warranty

Midland warrants the products of its own manufacture to be free of defects in material and workmanship, for a period of 1 year from the date of invoice. Furnished materials and accessories purchased from other manufacturers are warranted only by and to the extent of those manufacturers' warranties, if any.

MIDLAND MAKES NO WARRANTY OF ANY KIND WHATSOEVER, EXPRESS OR IMPLIED, OTHER THAN AS SPECIFICALLY STATED HERE. MIDLAND MAKES NO WARRANTIES OF MERCHANTABILITY OR FITNESS FOR ANY PARTICULAR PURPOSE OR USE. Midland's obligation under this warranty is strictly limited, at its option, to 1) repair or replacement at its factory of a like quantity of product: 2) refunding to

purchaser money paid to Midland for its product: or 3) issuance of written authorization for the Purchaser to repair or replace, at costs comparable to Midland's normal manufacturing costs those parts proven defective, provided that Purchaser has given to Midland immediate notice upon discovery of such defect. Merchandise claimed to be defective shall not be returned without first obtaining Midland's written consent. The undertaking of repair or replacement by the Purchaser, or its agents, without Midland's written consent, shall void Midland's warranty and relieve Midland of all responsibility. Under no circumstances shall Midland be liable for any direct, incidental, consequential or other damages of any kind in connection with the installation, operation, maintenance, repair, inspection or other use of any product purchased from it.



A **DOVER** RESOURCES COMPANY

Mail to: P.O. Box 226, Skokie, IL 60076-0226
7733 Gross Point Road, Skokie, IL 60076-0226
Phone: (847)677-0333, Fax: (847)677-0138